

LCU-SP Series

Shallow Pan Condensate Pump

Liberty Pumps®

A Family and Employee Owned Company

For removal of condensate from high efficiency furnaces, A/C equipment, ice machines, drinking fountains, beverage machines, dehumidifiers, and other applications requiring condensate removal



Features

- High impact ABS tank
- Wall mounts
- Three 1" intake holes
- 3/8" O.D. outlet
- Barbed and threaded discharge connection
- Removable check valve
- Stainless steel shaft
- 6' Power cord with ground
- Thermally protected
- Fully automatic
- Quiet operation
- Models with an "S" include built-in safety switch
- Models with a "T" include 20' of tubing
- Isolation pads pre-installed on tank



innovate. evolve.

LCU-SP Series

Applications

- High efficiency furnaces
- AC equipment
- Ice machine
- Drinking fountains
- Dehumidifiers
- Other applications requiring condensate removal

Max Fluid Temperature

150°F (65.5°C) Intermittent

Performance Curve

60 Hz

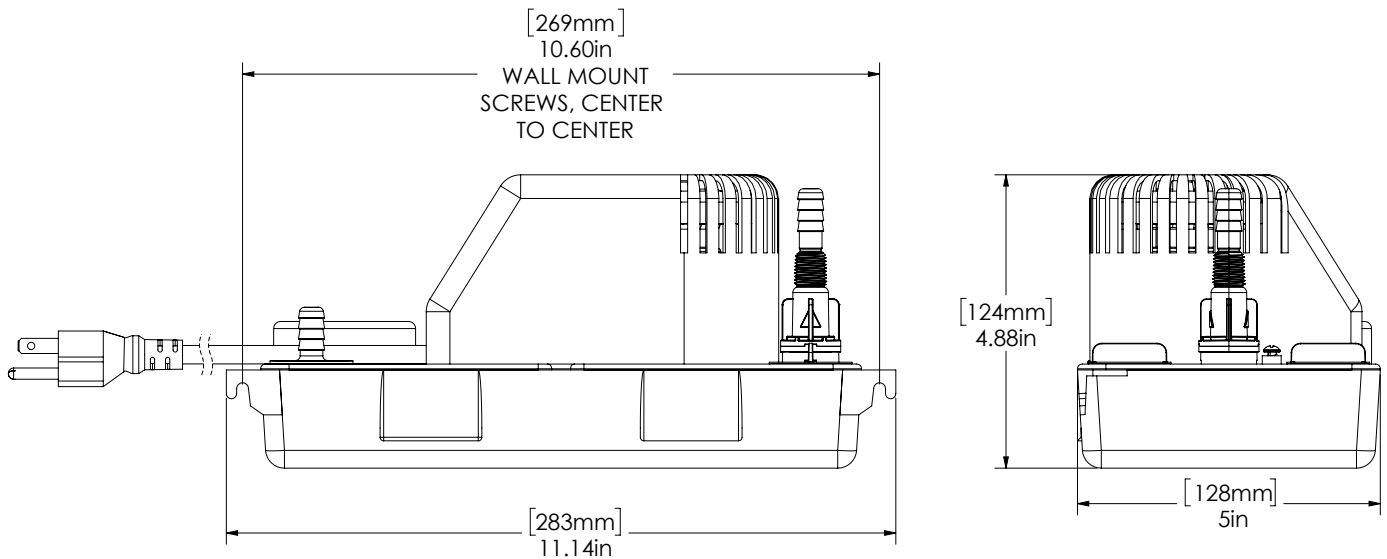
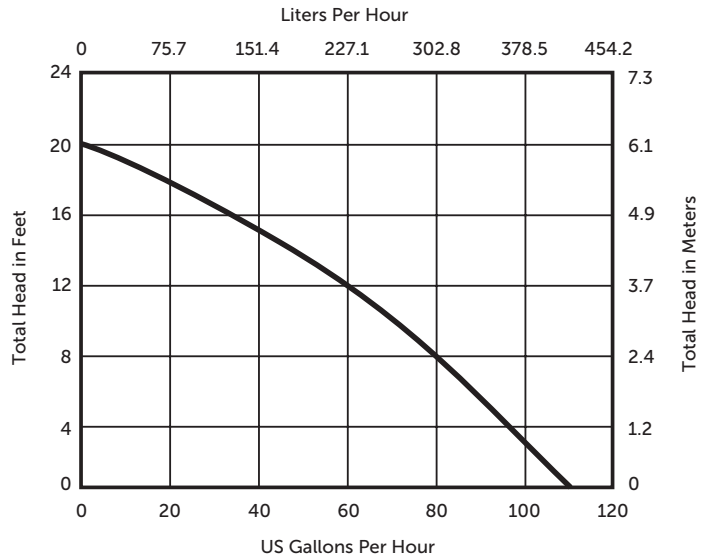

Models

MODEL	HP	VOLTS	AMPS	HEIGHT	LENGTH	WIDTH	WEIGHT IN LBS	CAPACITY	MAX HEAD	SAFETY SWITCH	20' TUBING
LCU-SP20S	1/30	115	1.5	5"	11-1/8"	5"	4.5	1 US Qt	20'	Yes	No
LCU-SP220S	1/30	230	0.7	5"	11-1/8"	5"	4.5	1 US Qt	20'	Yes	No